



## Cast Steel Globe Valve with Rising Handwheel and Stem

Impactor, Handwheel, the mechanism is based on transmitted the momentum generated but the mass of the handwheel through the impact/impulse generated during the snap closure action of the handwheel. This type of handwheel is used when a standard handwheel cannot create enough closing force to effect a seal.

Stem Nut replaceable in the line.

Revolving rising stem with precision ACME thread.

Stem packing is designed for optimum control of fugitive emissions leakage to the atmosphere. The ultra low emission leakage rate is assured by the fine finish in the stem, the reduced diametrical clearances and the stem straightness control.

Body-to-Bonnet Joint designed to apply a uniform load to the gasket to assure a leak proof seal.

Backseat designed to relieve back pressure on the stem packing when fully seated. Replacing stem packing under pressure is not recommended.

Conical Disc, integrally guided to assure true alignment between disc and valve body. The loose disc design allows the disc and seat rising sealing surface to seat correctly without damage.

Stellited Seat Ring, providing increased resistance to ware, abrasion and erosion of the sealing surface.

Seat rings are threaded/seal welded to provided a bubble tight joint.

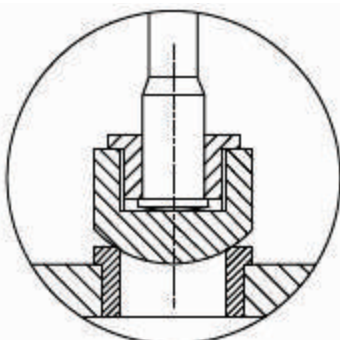
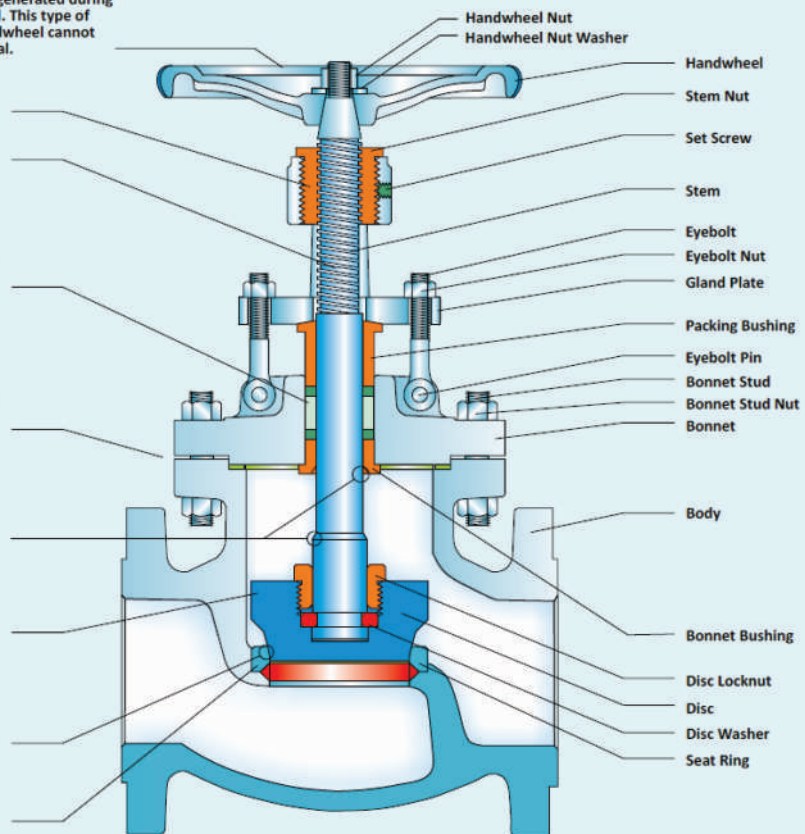

REGULATING DISC